

**Notes:**

1) All dimensions in inches.

2) Hot-dipped galvanized per ASTM A123.

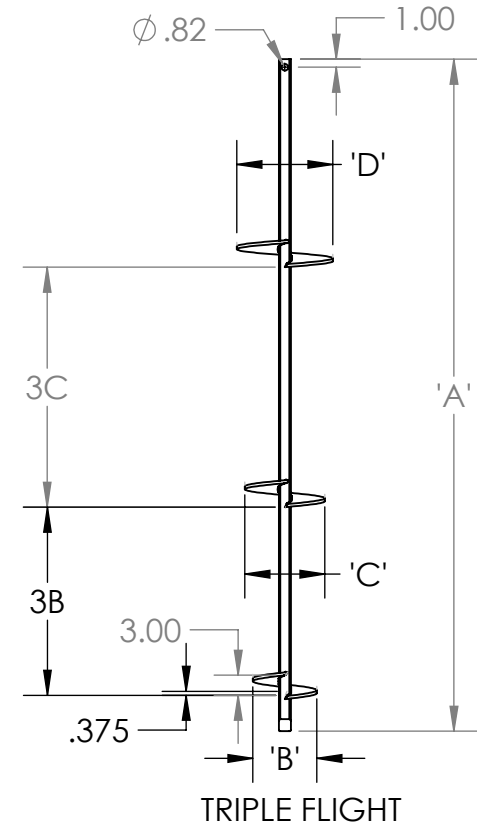
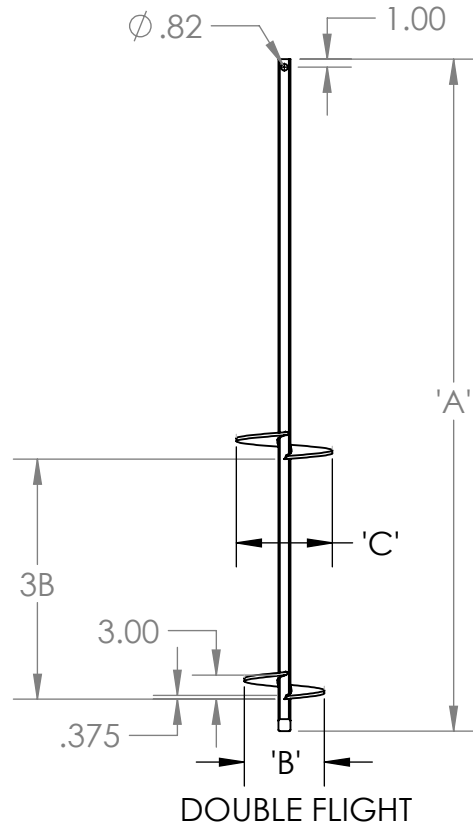
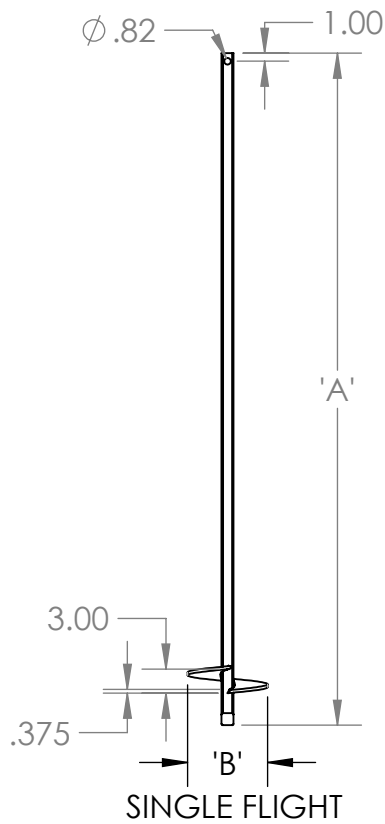

PART NUMBER	'A'	'B'	'C'	'D'	WEIGHT (LBS)	TORQUE RATING (FT-LBS)	TENSION RATING (LBS)
G667087	7'	8"	-	-	57	7,000	70,000
G667107		10"	-	-	60		
G667127		12"	-	-	64		
G667147		14"	-	-	68		
G66708107		8"	10"	-	65		
G66710127		10"	12"	-	72		
G66712147		12"	14"	-	80		
G6670810127		8"	10"	12"	77		
G66377		10"	12"	14"	89		

Unless otherwise noted:

All dimensions are in inches  
 Flush Callout +/- 1/8  
 Degrees: +/- 2.0  
 0. +/- 1/2  
 0.0 +/- 1/4  
 0.00 +/- 1/8  
 0.000 +/- 1/16

<b>C</b>	<b>5/1/2024</b>	<b>156</b>
<b>B</b>	<b>8/7/2023</b>	<b>112</b>
<b>A</b>	<b>1/18/2023</b>	<b>-</b>
<b>REV</b>	<b>REV DATE</b>	<b>ECR #</b>



**MATERIAL:** 1-1/2" ROUND CORNERED SQUARE STEEL BAR PER ASTM A29/A29M-16 & 3/8" STEEL PLATE PER ASTM A1018

POWER-GRIP 7' SQUARE SHAFT ANCHOR

**P/N:** POWER-GRIP 7' SQUARE SHAFT ANCHOR - DATA SHEET

**WEIGHT:** SEE TABLE

**Date:** 1/18/2023

**DRAWN BY:** JM

**Rev:** C